

EHB Series Precision Balance

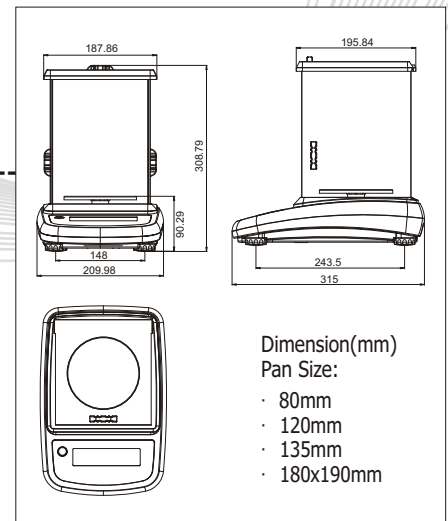

► Features:

- * 16.5mm digits high LCD display
- * Tare, hold, counting, percentage function
- * Rechargeable battery provide up to 40 hours of continuous use (without backlight)
- * Up to 300,000 resolution



► Specifications:

Model	EHB-M						EHB+		EHB++	
Display	16.5mm digits high LCD display									
Capacity	150g	300g	600g	1500g	3000g	6000g	200g	2000g	300g	3000g
Readability	0.002g	0.005g	0.01g	0.02g	0.05g	0.1g	0.001g	0.01g	0.001g	0.01g
Pan size	80mm	120mm		135mm		180 x 190mm	80mm	120mm	80mm	120mm
Max. Divisions	60,000d/6000e						200,000d		300,000d	
Keyboard	7 membrane keys									
Housing	ABS plastic									
Attachment	Wind shield			None			Wind shield			
ADC	Sigma delta									
ADC update	≤ 1/10 second									
Operate Temp	5°C~+40°C									
Power	AC adapter (12V/500mA) , Rechargeable battery(6V/1.2A)									
Gross weight	3.5kg			2kg			3.5kg			