

Smart Scale (LED)



Model: ES-R

Features

- ◆ Aluminium die-casting case
- ◆ Stainless steel shackle
- ◆ Alloy steel hook
- ◆ LED module display
- ◆ AA*4 batteries
- ◆ Optional colors
- ◆ Capacity: 100kg~1000kg

Description:

Size and Weight

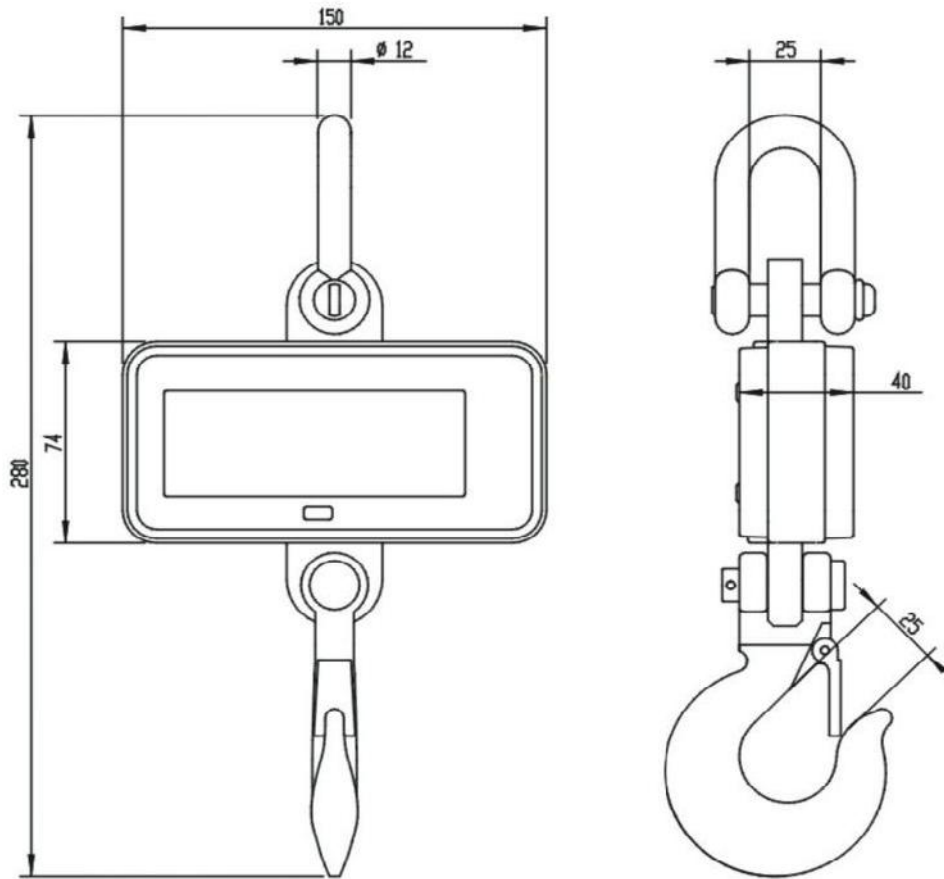

Functions

◆ Zero	◆ Battery supervision
◆ Tare	◆ Overload alarm
◆ Hold	◆ Unit switch
◆ Auto power-off	

Specification

Accuracy class	OIML III
Tare range	100%F.S.
Zero range	4%F.S.
Safe overload	120%F.S.
Overload alarm	100%F.S.+9e
Battery	AA*4
Battery life	>100h
Temperature range	-10℃ ~40℃

Package



Accessory



Remote control

