

QHW/QHWplus SERIES CHECK WEIGHING SCALES



► FEATURES

- 7 keys embossed membrane keyboard
- Function include check weighing, counting, percentage, accumulation and weighing units conversion
- Check weighing function (user can set hi/low limit for weighing, counting and percentage)
- Battery provide up to 90 hours of continuous use

► OPTIONS

- RS-232 can connect to computer, LP-50 Label printer or TPuP mini printer
- Setpoint output (relay)

► DIMENSION (mm)

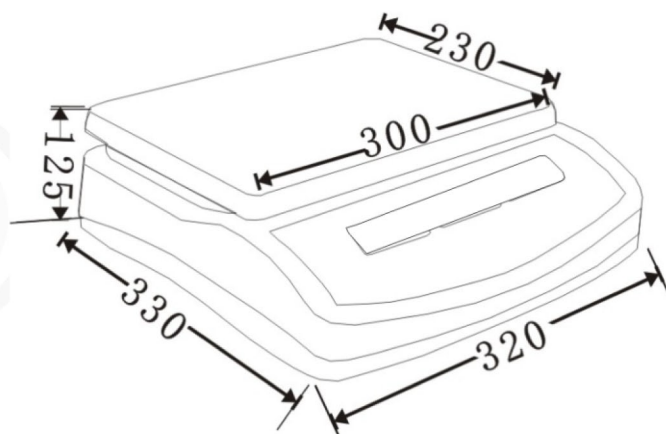

► SPECIFICATIONS

MODEL	QHW-3	QHW-3plus	QHW-6	QHW-6plus	QHW-15	QHW-15plus	QHW-30	QHW-30plus
Display	24mm LCD, with LED backlight							
Keyboard	7 keys embossed membrane keyboard							
Pan size	230mmX300mm							
Capacities	3kg		6kg		15kg		30kg	
Division	0.1g	0.05g	0.2g	0.1g	0.5g	0.2g	1g	0.5g
Tare range	3kg	1kg	6kg	6kg	10kg	10kg	30kg	10kg
Operate temp	0°C~+40°C							
ADC	sigma delta							
ADC update	≤1/10 second							
Housing	ABS plastic							
Max. Divisions	30,000/60,000d (approved version: 3000e or dual range)							
Power	AC adapter (9V/800mA) Internal rechargeable battery (6V/4Ah)							
Gross weight	5.1kg							