

# QHW++ HIGH PRECISION WEIGHING SCALES

## ► FEATURES

- Special NMB load cell, bring top high precision
- 7 key embossed membrane keyboard
- Function include check weighing, counting, percentage, accumulation and weighing units conversion
- Check weighing function (user can set hi/low limit for weighing, counting and percentage)
- Battery provide up to 90 hours of continuous use

## ► OPTIONS

- RS-232 interface, can connect to computer, LP-50 Label printer or TPuP mini printer

## ► DIMENSION (mm)

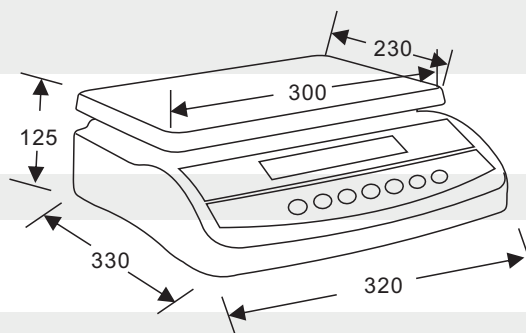

## ► SPECIFICATIONS

Model	QHW-15++	QHW-30++
Display	24mm LCD, with LED backlight	
Keyboard	7 keys embossed membrane keyboard	
Pan size	230mmx300mm	
Capacities	15kg	30kg
Division	0.1g	0.2g
Tare range	9.999kg	9.998kg
Operate temp	0°C~+40°C	
ADC	sigma delta	
ADC update	≤1/10 second	
Housing	ABS plastic	
Power	AC adapter (9V/800mA) Internal rechargeable battery (6V/4Ah)	
Gross weight	5.1kg	
Packing	Master carton 4 in 1 Gross weight 23.5kg dimension 0.162 m <sup>3</sup> , 40 feet container can load 1320 machine, 20 feet container can load 660 machine	